

ROBERTS



RT100

**Turntable with USB connection
and built-in preamplifier**

Please read this manual before use

Contents

<i>RT100 turntable features</i>	2
<i>Unpacking the turntable</i>	3
<i>Assembling the turntable (part 1)</i>	4
<i>Setting the tracking force</i>	5-6
<i>Assembling the turntable (part 2)</i>	7
<i>Mains adaptor</i>	8-9
<i>Connecting the turntable</i>	9-10
<i>Playing a record</i>	11-12
<i>Frequently asked questions</i>	13-14
<i>Recording using a computer</i>	15-16
<i>General</i>	17
<i>Safety instructions</i>	17
<i>Specifications</i>	18
<i>Cartridge and stylus</i>	18
<i>Guarantee</i>	Back page

RT100 turntable features

- 1. Counterweight**
This is used to set the tracking force.
- 2. Anti-skating control**
This is used to set the anti-skating force.
- 3. Cueing lever**
Use this lever to lower and raise the tone-arm.
- 4. Tone-arm rest and securing clip**
This holds the tone-arm in place when not in use.
- 5. Head-shell**
This holds the cartridge and stylus.
- 6. 33 / 45 r.p.m. speed switch**
Selects the speed for the record to be played.
- 7. Platter and rubber mat**
Place the record here for playing.
- 8. Phono sockets (right and left)**
Audio output to an amplifier.
Red = Right channel; White = Left channel.
- 9. Pre-Amp On/Off Switch**
Controls use of the built-in phono preamplifier.
If connected to a Line or Aux input set this switch to On.
- 10. USB port**
Connect to a computer for making recordings.
- 11. Auto Stop On/Off switch**
Controls the use of the automatic switch off.
- 12. DC input socket**
- 13. Power On/Off switch**

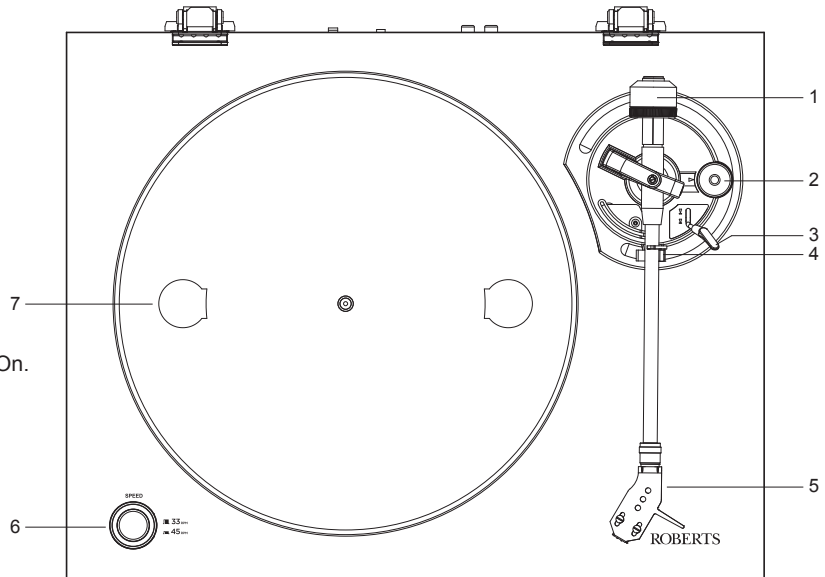
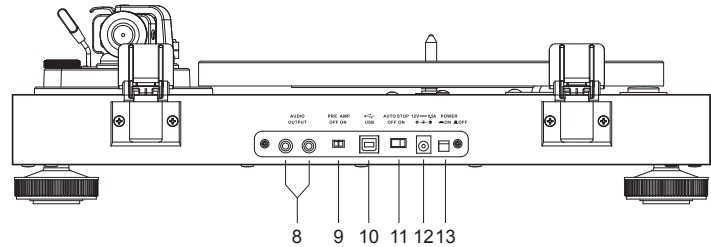

Unpacking the turntable

1. Clear a work area, such as a dining table, in which to unpack the turntable.
2. Ensure the packaging is the right-way up.
3. Open the packaging carefully.
4. Lift out each item, identify it, and carefully place to one side.
 - Top cover
 - Base unit with tone-arm
 - Turntable platter with belt
 - Rubber mat
 - Head-shell with cartridge
 - Counterweight for the tone-arm
 - Hinges x 2
 - Cables x 3, comprising
 - USB cable (type-A – type-B)
 - Stereo phono plugs – Stereo phono plugs
 - Stereo phono sockets – 3.5mm stereo plug
 - Mains power adaptor with EU and UK pin options
5. We recommend that all packaging is kept to allow the turntable to be safely transported in the future.

Assembling the turntable (part 1)

1. Unwrap the base unit, taking care not to put pressure on the tone-arm or the cueing lever.
2. **Do not assemble the platter onto the base just yet.** There is less chance of damage to the cartridge and stylus if the tone-arm is assembled and balanced first.
3. Ensure that the tone-arm is locked on its rest with the securing clip.
4. Take the head-shell and identify the locating pin on the head-shell connector. **Do not remove the stylus cover at this time.**
5. Align the locating pin on the head-shell connector with the slot in the socket at the end of the tone-arm.
6. Gently push the head-shell into the tone-arm, at the same time rotate the locking ring at the end of the tone-arm to pull the two parts together. Note that the locking ring rotates anti-clockwise when viewed from the front.
7. Tighten the locking ring gently by hand. Do not apply force or use any tools.
8. Slide the counterweight on to the tone-arm, rotating it clockwise when viewed from the rear until it engages and some slight resistance is felt.
Note that the scale on the counterweight rotates freely. The counterweight itself must be rotated in order to engage correctly with the tone-arm.

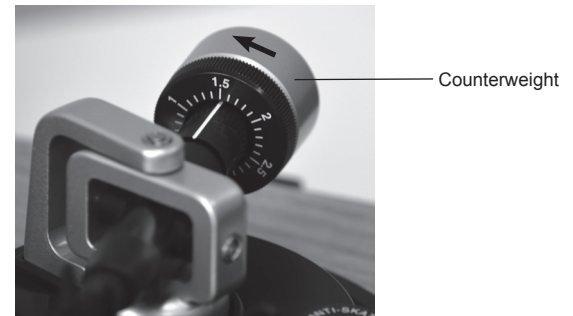
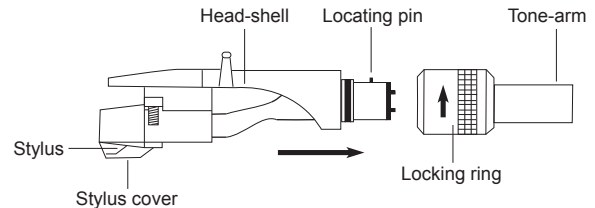
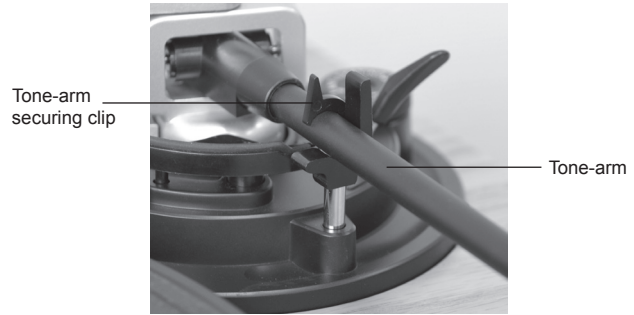

Setting the tracking force

1. Set the anti-skating control to zero.
2. Raise the cueing lever.
3. Unclip the tone-arm from its securing clip so that it can move freely.
4. Take the head-shell and observe that it is currently unbalanced. At this point the head-shell should drift upwards.
5. Rotate the counterweight so that it moves further onto the tone-arm.
6. Keep checking the balance by lowering the cueing lever to see whether the tone-arm falls, rises or remains level. Take care when lowering the tone-arm that the stylus does not come into contact with the turntable base.
You should ignore the scale on the front of the counterweight at this time.
7. Adjust the counterweight further by rotating the counterweight so that it moves in or out until the tone-arm is balanced and remains level when the cueing lever is lowered.
8. Carefully remove the stylus cover and adjust the counterweight again until the tone-arm is balanced.

When removing the stylus cover, take care not to touch the stylus.

When balancing the tone-arm it is important to ensure that the stylus never contacts the turntable platter, mat or turntable base.

Damage caused to the stylus by mishandling is not covered by the guarantee.



Setting the anti-skating control to zero

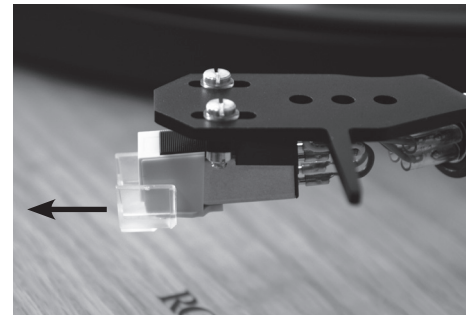
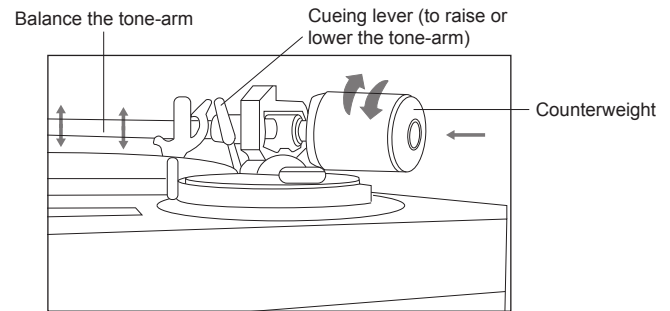

Removing the stylus cover

Setting the tracking force cont.

9. When you have balanced the tone-arm, place it so that it is again secured on its rest using the securing clip.
10. Carefully replace the stylus cover.
11. Keeping the counterweight in place, rotate the scale on the front of the counterweight so that it reads zero.
12. We recommend that a tracking force of 3.0 grams is used for the supplied cartridge. The tracking force should not exceed 4.0 grams.
The counterweight adjusts the tracking force by 3.0 grams for one complete revolution. Therefore the scale on the counterweight will read zero when the tone-arm is balanced and also when the tracking force is set to 3.0 grams.
13. Rotate the counterweight and scale together (clockwise, viewed from the rear) so that the counterweight moves further towards the tone-arm pivot and so that the scale then reads the desired tracking force.
Please see the photos to the right showing the counterweight setting when first balanced and then after setting the tracking force. Note that the counterweight is closer to the tone-arm pivot after setting the tracking force.
14. Adjust the anti-skating control next to the tone-arm pivot so that it also reads 3.0 grams. Note that this adjustment should normally be set to match the chosen tracking force.

Note: Incorrect tracking force can have a significant effect on the quality of audio when playing records. If the tracking force is set too low or too high then excessive wear to the stylus or damage to the surface of the record may be caused.

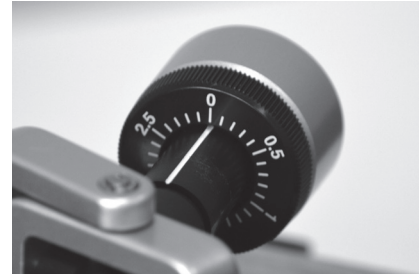

Scale set to zero after balancing the tone-arm

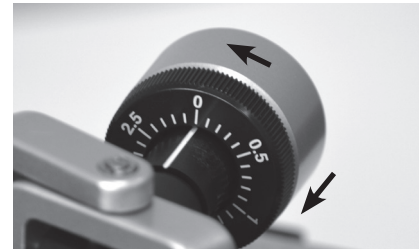

Scale reads zero after setting to 3.0 grams



Anti-skating control set to 3.0 grams

Assembling the turntable (part 2)

1. Unpack the platter and identify the drive belt.
2. Place the platter on the spindle. Use one of the holes in the platter to access the drive belt and place it over the pulley of the drive motor.
3. Slowly rotate the platter by hand to ensure that it moves freely and that the belt is not twisted.
4. Place the rubber mat on the platter.
5. Fit the two hinges onto the top cover. Note that the hinges are sprung and will tend to spring away from the cover.
6. Locate the other end of the hinges in the two sockets at the rear of the turntable base.

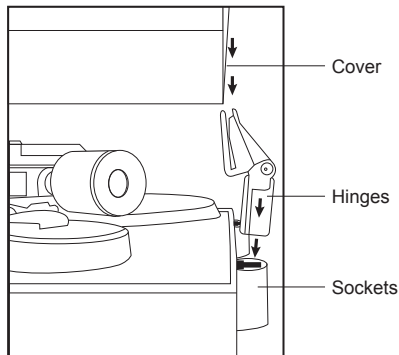

7. Lower the cover into place over the platter and tone-arm.

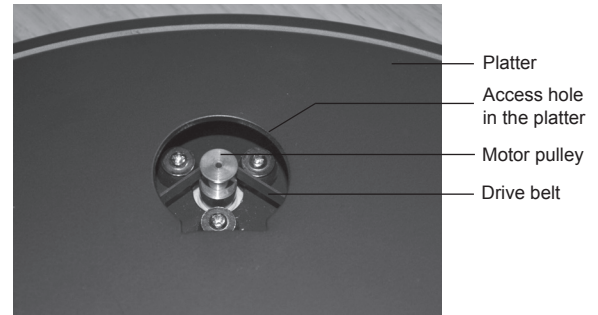

Mains adaptor

1. Assemble either the UK or EU pins onto the mains power adaptor to suit the mains sockets installed at your location.
2. Note that the rounded end of the pins section needs to engage with the adaptor before the rectangular end.
3. It is important to check that the pins are fully secured to the adaptor before it is used.
4. Plug the DC lead from the mains adaptor into the DC input socket on the back of the turntable.
5. Plug the adaptor into a suitable mains socket.

The AC adaptor should be disconnected from the mains supply and from the turntable when not in use.

IMPORTANT: The mains adaptor is used as the means of connecting the product to the mains supply. The mains socket and any multi-way mains block used for the product must remain accessible during normal use. In order to disconnect the product from the mains, the mains adaptor should be removed from the mains socket completely.

Use only the mains adaptor provided with the product, or a genuine replacement provided by Roberts Radio. The use of alternative adaptors will invalidate the guarantee.

6. Switch on at the mains socket and then switch on using the **Power On/Off** switch next to the DC input socket.

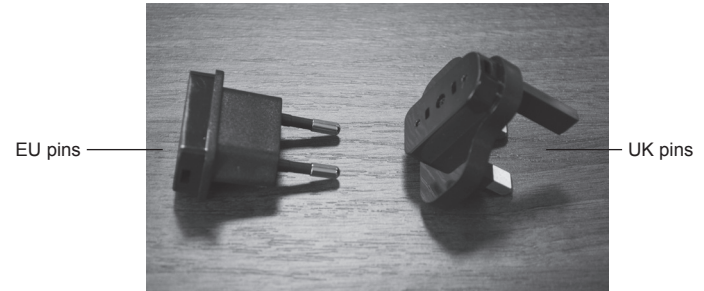

AC adaptor assembled with UK pins

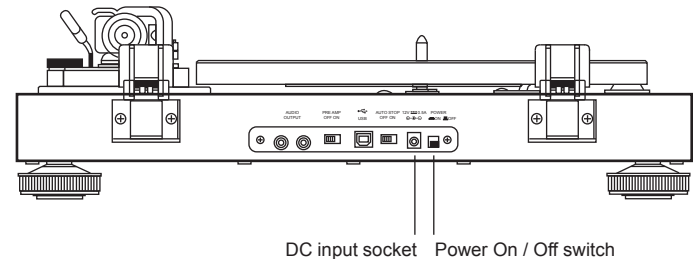
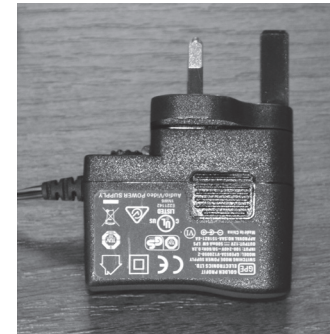

Mains adaptor cont.

7. Release the tone-arm securing clip.
8. Raise the cueing lever fully to raise the tone-arm.
9. Move the tone-arm towards the platter.
10. Observe that the platter rotates, and that its speed changes according to the speed switch setting.
11. Return the tone-arm to its rest and secure it.
12. Observe that the platter stops rotating.

Connecting the turntable

The turntable cannot play music without being connected to a device providing amplification and one or more loudspeakers. This device may be a hi-fi system, a radio or sound system, a soundbar, a multi-room speaker, or just about any audio device with a spare auxiliary input.

Many Roberts products are compatible with the turntable. These include the Revival RD60 radio, the Blutune 200 sound system, and the Stream 93i internet radio. The turntable can also be connected to all Roberts R-Line multi-room products such as the SB1 soundbar or the RS1 streamer which allows connection to a hi-fi system and to multi-room components at the same time.

1. If you are connecting the turntable to a hi-fi amplifier or receiver with a built-in phono preamplifier you should set the Pre-amp switch on the back of the turntable to Off. In all other cases you should set the Pre-amp switch on the back of the turntable to On (as shown).
2. Using the supplied audio cables, connect two phono sockets on the back of the turntable to the Auxiliary input, Line input or Phono input on the chosen amplifying device.



Connecting the turntable cont.

To connect to a hi-fi system you would typically use the cable with phono plugs at each end.

To connect to devices with an auxiliary input you would typically use the cable with phono plugs at each end in combination with the short adaptor cable to convert the connection to a 3.5mm plug.

3. Switch on the amplifying device and select the input to which you have connected the turntable. Select a moderate volume level.
4. At this point, nothing should be heard. If there is audible hum, check that all of the plugs and sockets are securely connected.

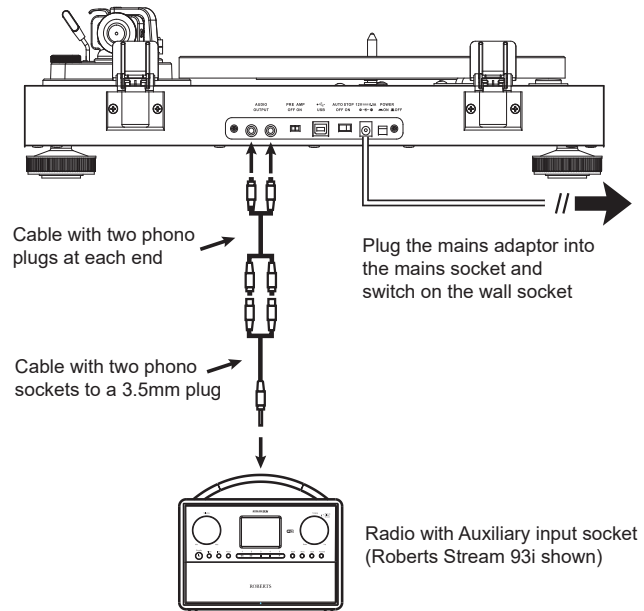
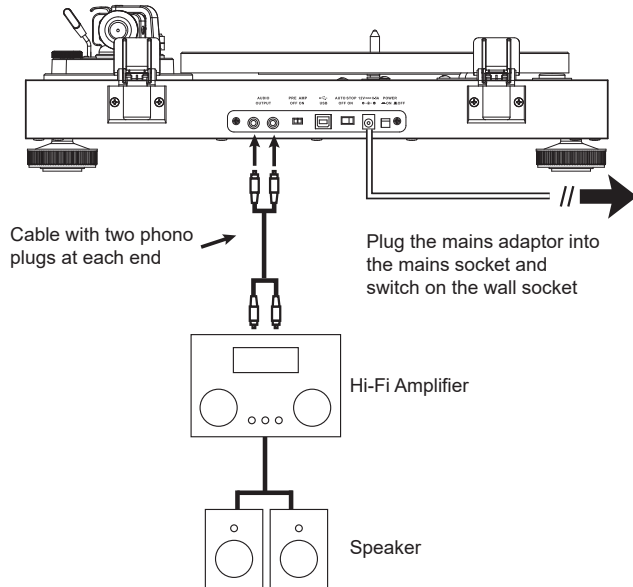

Playing a record

1. Ensure that the record is clean and dust free. Use a record cleaner if required.
2. Carefully place the record on the platter and set the speed switch to 33 or 45 r.p.m. as needed for the record.
3. Carefully remove the stylus cover by pulling it forwards.
4. Unclip the tone-arm securing clip.
5. Raise the cueing lever fully to raise the tone-arm.
6. Position the tone-arm so that the stylus is centred above the lead-in area of the record.
7. Lower the cueing lever. The tone-arm will drop slowly and the stylus should then settle into the groove at the start of the record which will then start playing.
8. You may wish to gently lower the dust cover while the record is playing. Do not let it close suddenly to avoid a sudden jolt to the tone-arm and stylus.

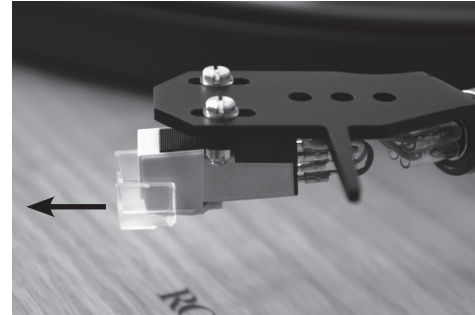
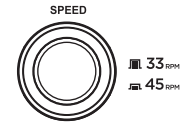

Removing the stylus cover



Stylus positioned over the lead-in groove just before playing

Playing a record cont.

9. Provided that you have everything connected correctly, you will be able to listen to the record through your connected equipment (see page 10).

10. At the end of the record, the turntable will switch off.

Note that the automatic switch off feature is dependent on the placement of the run-out groove at the end of the record and may take a few seconds to operate. In the event that the turntable switches off prematurely, you will need to set the Auto Stop switch on the rear panel to Off.

11. Raise the cueing lever and return the tone-arm to its rest. The platter may rotate briefly during this step.

12. Lock the tone-arm in place with the securing clip.

13. If not playing another record for a while, it is recommended to close the dust cover, to switch off the DC power switch at the back of the turntable, and to switch off the mains supply to the turntable.

14. If you wish to stop playing a record before it has finished, use the cueing lever to raise the stylus from the record before returning the tone-arm to its support.

Note: Always use the cueing lever to lower and raise the tone-arm and stylus in order to minimise the risk of damage to either the stylus or the record's surface.

When playing records it is important to ensure that the stylus never contacts the turntable platter, mat or turntable base.

Damage caused to the stylus by mishandling is not covered by the guarantee.

AUTO STOP
OFF ON



Automatic stop enabled

AUTO STOP
OFF ON



Automatic stop disabled

Frequently asked questions

1. Why is the sound very distorted when playing a record?

- Check that the turntable is connected to a suitable input on the connected device.
- Check whether you have connected the turntable to a phono input on your amplifier. If so, ensure that the pre-amp switch on the turntable is set to Off.
- Check the tracking force and anti-skating adjustment (see page 6).
- Check there is no dust or dirt accumulating on the stylus. If so, carefully clean the stylus using a proper stylus cleaning brush or try to blow the dust off the stylus. (Do not use your fingers.)

2. Why is the sound very quiet when playing a record?

- Check that the turntable is connected to a suitable input on the connected amplifying device and that the connections are secure.
- If using an Auxiliary input or Line input, ensure that the pre-amp switch on the back of the turntable is set to On.
- Check that the volume on the amplifying device is set appropriately.

3. Can I use an external preamplifier rather than the one built into the turntable?

- Yes. Set the pre-amp switch on the rear of the turntable to off. If the external preamplifier has a Moving Magnet or Moving Coil option (this may be marked as MM or MC) ensure that the Moving Magnet option is selected.

4. Why does the turntable not always switch off at the end of a record?

- Check that the Auto-Stop switch on the back of the turntable is set to the On position.
- The operation of the Auto Stop function is dependent on the location of the run-out groove at the end of the record. Even if the turntable does switch off, you should return the tone-arm to its support after playing a record. Failure to switch off after playing some records is not a fault of the unit.

Frequently asked questions cont.

5. Why doesn't the tone-arm return to the rest automatically at the end of the record?

- While this feature was common on basic domestic turntables in the 1960s and 1970s, it is very uncommon in modern turntables. The mechanisms needed to lift and move the tone-arm in this way tend to detract from the quality of the audio available from the turntable since they also require that the design of the drive system and the tone-arm mechanism is more robust and therefore heavier than otherwise needed.

6. How often should I replace the stylus?

- We recommend that the stylus is replaced approximately every 250 playing hours. Normal wear on the stylus caused playing records is not covered by the guarantee.
- The cartridge supplied with the turntable is an Audio Technica model AT-3600L. Suitable styli for this cartridge are available from hi-fi stockists and many suppliers on the internet. The stylus supplied is Audio Technica model number ATN-3600L.
- Note that there is no need to remove the cartridge from the head-shell in order to replace the stylus. However, this task may be easier if the head-shell is removed from the tone-arm before changing the stylus. Removal is simply the reverse of the installation process (see page 4).

7. How do I clean the turntable?

- To clean the turntable use a soft lint-free cloth, ideally made from natural fibres in order to prevent a build-up of static electricity which can attract dust.
- Do NOT use polish or any solvent based cleaners.
- To remove dust from the mat on the platter, use a slightly damp lint-free cloth, removing the mat first if needed.
- To clean records, only use a purpose designed record cleaning brush with the record on the platter.

Recording using a computer

The RT100 turntable has a USB connection which allows digital recordings to be made of records that you own, so that you may later play them from other devices such as a smartphone or digital audio player. Note that there are many ways to make a recording from a record using a computer or similar platform. It is beyond the scope of a user guide such as this to cover all aspects of the process and the many different software applications that can be used for this task. We have outlined a method here using a PC with Windows 10 to allow you to understand the basic steps. For many users this will be more than sufficient, but there are also many resources and guides available on the internet for those who use other platforms or who wish to explore and gain a deeper understanding.

For this exercise, we suggest that you use the audio recording and processing program called Audacity. It is free, and it is available from <http://www.audacityteam.org/> for Windows, Mac OS and Linux. (Linux users may need to search for pre-built binaries or may build their own.)

1. Install Audacity on your computer from the official web site:

<http://www.audacityteam.org/download>

2. Switch on the turntable at the mains socket and then switch on using the **Power On/Off** switch next to the DC input socket.
3. Connect the turntable to your PC using the USB cable provided.
4. Windows 10 will identify the turntable and will automatically install the necessary drivers.
5. Start the Audacity program.
6. In the source selection box in Audacity select 'Line (USB AUDIO CODEC)' as the source to be used.
7. Check that the recording level is at maximum (as shown here).
8. Prepare your record for playing.
9. Ensure that the Pre-amp switch at the back of the turntable is set to On to ensure a correct digital output to your computer. If the turntable is also connected to an audio system with a built-in phono pre-amplifier (see pages 9-10), you should either lower the volume on the audio

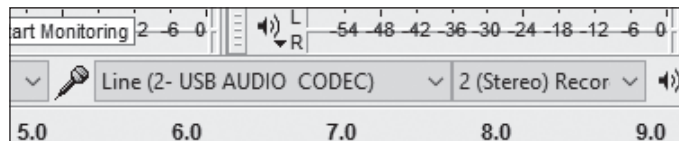

Step 6 - USB AUDIO CODEC selected as the recording source with two channel (stereo) capability

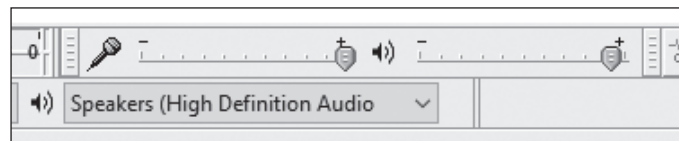

Step 7 - Recording level adjustment (showing level = 1.0)

Recording using a computer cont.

system or switch it off, since the two preamplifiers in the turntable and the audio system will result in distorted sound from the audio system. In this case you would set the switch back to Off after recording.

10. Lower the tone-arm to allow the record to play and then click on the Record icon in Audacity.
11. Allow the record to play. You should see that Audacity is receiving audio from the turntable and scrolls the corresponding data across the screen. Lower the recording level if the waveform shows clipping.
12. At the end of the record, click the Stop icon.
13. To save the complete recording to your computer, select Export Audio from the File menu. Chose the format in which you wish the audio to be exported (FLAC, MP3, etc.) and save the file.
14. To generate a file for each track of the record, we suggest the following process.
 - a. Use the audio zoom and selection tools in Audacity to select the audio for the track to be saved.
 - b. From the File menu, export the current selection in the required format.
 - c. Repeat the above two steps until all required tracks have been saved.
15. If necessary you can use the filter effect options within Audacity to remove any pops and clicks from the recording.

For more detail on the use of Audacity, there is comprehensive documentation on the Audacity site at

<http://www.audacityteam.org/help/documentation/>

Even if your vinyl collection is old, please respect the copyright of the original artists and publishers.

Basic controls in Audacity

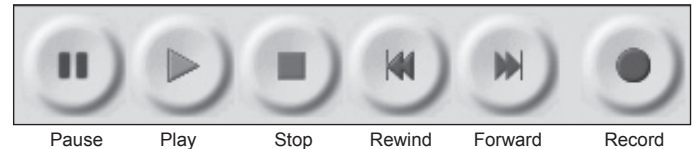

Check the recording level

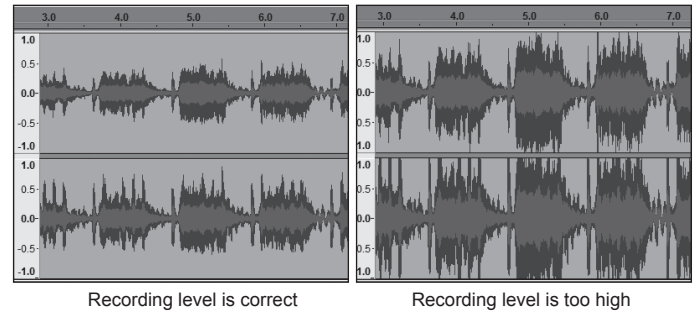

Audio zoom and selection controls in Audacity

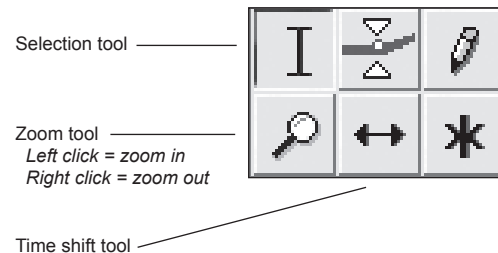

General

Do not allow this turntable to be exposed to water, steam or sand. Do not leave your turntable where excessive heat could cause damage such as in a parked car where the heat from the sun can build up even though the outside temperature may not seem too high.



The name plate is located underneath the turntable.

Safety instructions

- Your turntable and AC/DC adaptor should not be exposed to dripping or splashing and no objects filled with liquids, such as vases, shall be placed on the turntable or adaptor.
- It is recommended to operate the product such that there is a minimum distance (10cm recommended) to adjacent objects in order to ensure good ventilation.
- The ventilation of the product should not be restricted by covering it or its ventilation openings with items such as newspapers, tablecloths, curtains etc.
- No naked flame sources such as lighted candles should be placed on the product.
- It is recommended to avoid using or storing the product at extremes of temperature. Avoid leaving the unit in cars, on window sills, in direct sunlight etc.
- There are no user serviceable parts inside this product. The drive belt, stylus and cartridge are considered to be parts that the user may replace if so desired.
- Do not attempt to disassemble any part of the product.
- The product must be used in a moderate climate.

Specifications

Power Requirements

Mains AC 100 ~ 240 volts, 50/60Hz (adaptor)
(Use only the supplied adaptor)

Dimensions

Cover closed:

Width = 448mm

Height (including cover) = 140mm

Depth (including hinges) = 366mm

Cover open:

Width = 448mm

Height (including cover) = 425mm

Depth (including cover) = 415mm

Cartridge and stylus

Cartridge

Moving magnet type
Audio Technica AT-3600L
Load impedance 47kΩ

Tracking force

3.0 - 4.0 grams

Replacement stylus

Audio Technica ATN-3600L

The Company reserves the right to amend the specification without notice

Guarantee

This product is guaranteed for twenty four months from the date of purchase by the original owner against failure due to faulty workmanship or component breakdown, subject to the procedure stated below. Should any component or part fail during this guarantee period it will be repaired or replaced free of charge.

The guarantee does not cover:

1. Damage resulting from incorrect use.
2. Consequential damage.
3. Product with removed or defaced serial numbers.

N.B. The stylus will not be replaced under this guarantee if it is damaged or broken.

Procedure:

Any claim under this guarantee should be made through the dealer from whom the product was purchased. It is likely that your Roberts dealer will be able to attend to any defect quickly and efficiently, but should it be necessary the dealer will return the product to the company's service department for attention. In the event that it is not possible to return the product to the Roberts dealer from whom it was purchased, please contact Roberts Radio using the contact details on the www.robertsradio.com website.

For product repairs falling outside the guarantee period, please refer to the "customer care" tab on the www.robertsradio.com website.

These statements do not affect the statutory rights of a consumer.

ROBERTS RADIO LIMITED

PO Box 130
Mexborough
South Yorkshire
S64 8YT

Website: <http://www.robertsradio.com>

